

### Models

OSS-20

### Description

The OSS-20 extends your BACnet or Modbus network when your application requires additional inputs and outputs on a physical controller. Combining the 20 inputs and outputs of the CMMB with your Building Automation System provides simple expansion of a new or existing controller and reduces unnecessary costs of additional components.

### Features

#### Power & Communication

- 24Vac or 30Vdc supply
- BACnet® MS/TP or Modbus communication port (selectable)
- Up to 2 STLD24 thermostats

#### Inputs & Outputs

- 8 universal inputs
- 2 digital inputs
- 2 universal outputs (supervised)
- 2 analog outputs (supervised)
- 6 digital outputs (supervised)

#### Installation

- 10 override switches to manually control each output
- LED status indication of each input and output
- DIN rail mounting
- Removable, non-strip, raising clamp terminals



OSS-20

### Network Communication

- BACnet® MS/TP or Modbus communication port (selectable via DIP switch)
- Select MAC address via DIP switch or via network

#### BACnet®

- MS/TP @ 9600, 19200, 38400 or 76800 bps
- Automatic baud rate detection
- Automatic device instance configuration
- Copy & broadcast configuration to other CMMB modules

#### Modbus

- Modbus @ 9600, 19200, 38400 or 57600 bps
- RTU Slave, 8 bits (configurable parity and stop bits)
- Connects to any Modbus master

### Technical Specifications

Specifications	CMMB106
Thermostats	Up to 2 STLD24 thermostats (via independent Modbus network), via 4-wire connection
Input Voltage	24 Vac or 27-33 Vdc
Consumption	5VA (331mA @ 24 Vac)
Universal Inputs (12-bit)	8 [0-10Vdc, 10KΩ (Thermistor type III), on/off (dry contact), 4-20mA] / 12-bit resolution
Digital Inputs	2 [normally open/closed or direct/reverse] / 12-bit resolution
Universal Outputs	2 [0-10Vdc, pulsed signal (20mA drive), on/off, 4-20mA] / 12-bit resolution
Analog Outputs	2 [0-10Vdc] / 12-bit resolution
Digital Relay Outputs	6 [normally open/closed, independent common per relay, 5A resistive]
BACnet	BACnet® MS/TP @ 9600, 19200, 38400 or 76800 bps (BAS-C)
Modbus	Modbus RTU slave @ 9600, 19200, 38400 or 57600. Selectable parity and stop bit configuration: <ul style="list-style-type: none"> <li>• No parity, 2 stop bit</li> <li>• Even parity, 1 stop bit</li> <li>• Odd parity, 1 stop bit</li> </ul>
Communication Connections	24 AWG twisted-shield cable (Belden 9841 or equivalent)
Electrical Connections	0.8 mm <sup>2</sup> [18 AWG] minimum
Operational Temperature	0°C to 50°C [32°F to 122°F]
Storage Temperature	-30°C to 50°C [-22°F to 122°F]
Relative Humidity	5 a 95% non condensed
Weight	0.4 kg [0.9 lb]

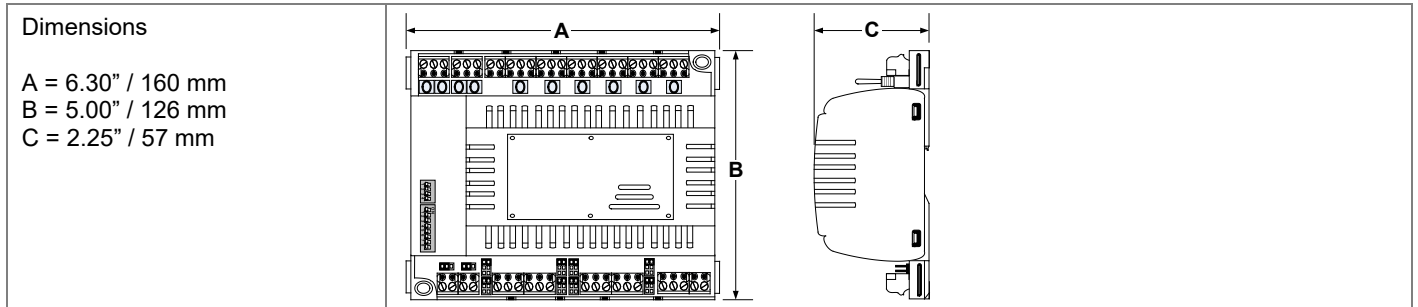

### Connections and Configurations

Please note that all jumper settings must also be set to the same value through BACnet. Some additional configurations are only available through BACnet (see Network Conditions on page 5).

### MAC Address | DS2

The 8 DIP switches represent a binary logic to calculate the MAC address.

Default = all OFF

BACnet all OFF = 0  
Modbus all OFF = 1

### End of Line | JP3 / JP4

120 Ohms  None\*

\* default setting

### Network Port | TB10

A+: BACnet/Modbus A+  
B-: BACnet/Modbus B-

### STLD24 Port | TB11

\*\* 2 STLD24 thermostats \*\*

A+: Modbus A+  
B-: Modbus B-

### Universal Inputs | TB12-15

\*\* Selectable \*\*

AI1: Universal Input 1  
COM: Common  
AI2: Universal Input 2

AI3: Universal Input 3  
COM: Common  
AI4: Universal Input 4

AI5: Universal Input 5  
COM: Common  
AI6: Universal Input 6

AI7: Universal Input 7  
COM: Common  
AI8: Universal Input 8

### Digital Inputs | TB16

\*\* Configurable \*\*

DI1: Digital Input 1  
COM: Common  
DI2: Digital Input 2

### Voltage Input | TB17

\*\* 100mA max \*\*

COM: Common  
24V: 24 Vac or 27-33 Vdc

### Network | DS1

4	Mode
OFF	BACnet*
ON	Modbus

3	Mode Options
<i>If BACnet</i>	
OFF	Auto Detect*
ON	Manual (see DS1-1 & DS1-2)

<i>If Modbus</i>	
OFF	Config via Modbus Register
ON	No parity, 2 stop bits

\* default setting

### Baud Rate | DS1

1	2	Result
OFF	OFF	9,600
ON	OFF	19,200
OFF	ON	38,400
ON	ON	BACnet: 76,800 Modbus: 57,600

### AO3-AO4 Signal | JP1-JP2

0-10 Vdc\*

4-20 mA

\* default setting

### Universal Outputs | TB1

\*\* Selectable \*\*

AO4: Universal Output 4  
COM: Common  
AO3: Universal Output 3

### Analog Outputs | TB2

\*\* 0-10 Vdc \*\*

AO2: Analog Output 2  
COM: Common  
AO1: Analog Output 1

### Digital Outputs | TB4-9

NC: Normally Closed  
COM: Common  
NO: Normally Open

### AI1-AI8 Signal | JP5-JP12

I = 4-20mA

T\* = 10K Ohms / on-off

V = 0-10Vdc

\* default setting

### AO1-AO4 Switches | SW1-SW4

Off = 0Vdc / 0mA

Auto\* = Automatic

On = 10Vdc / 20mA

\* default setting

### DO1-DO6 Switches | SW5-SW10

Off = Deactivated (normal state)

Auto\* = Automatic

On = Activated (opposite state)

\* default setting

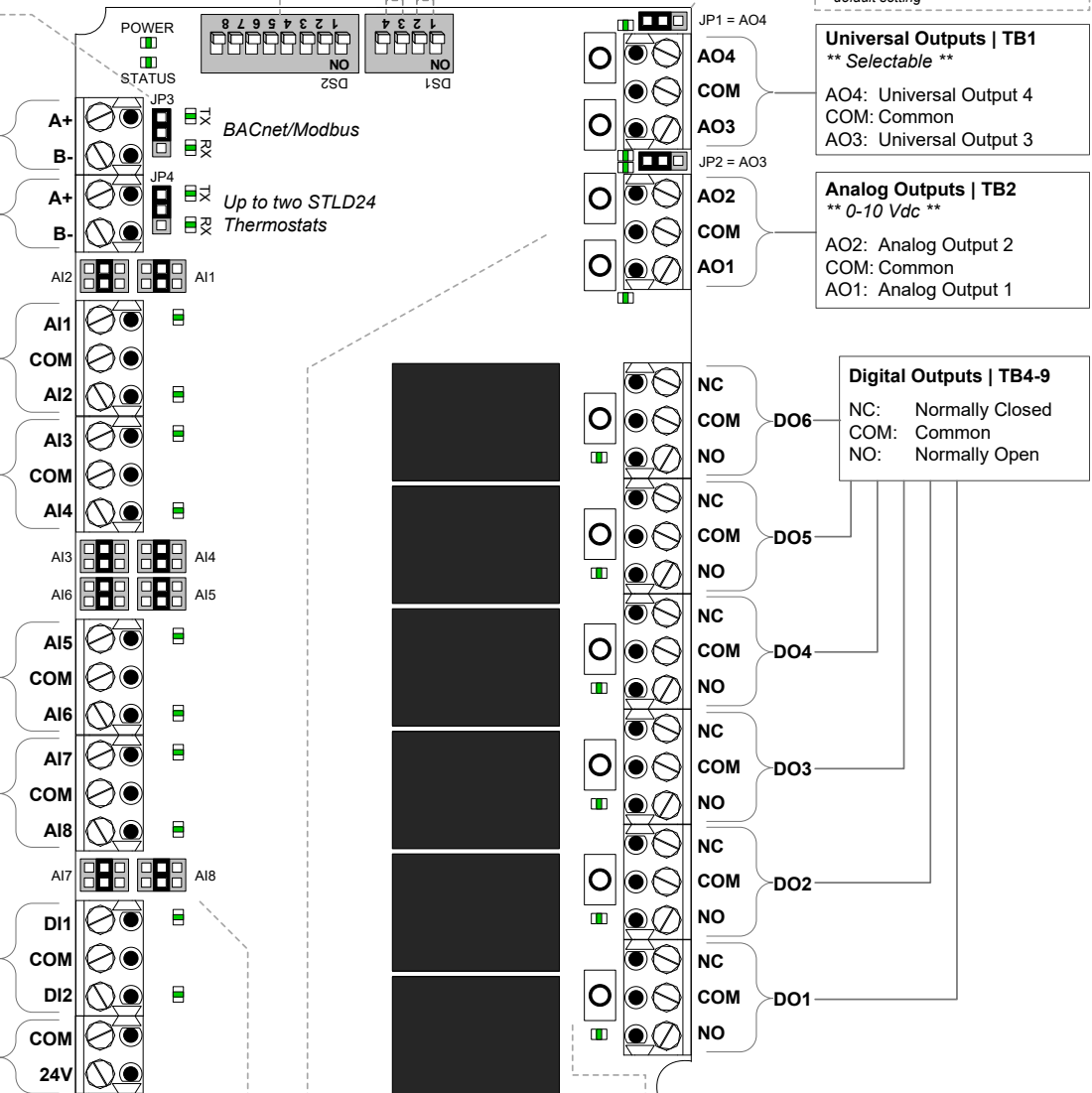

### MAC Address DIP Switch (DS2)

MAC address for BACnet and Modbus communication, are selectable by DIP switch DS2 using binary logic.

#### BACnet

- Highest MAC address is 254.
- Default is all switches OFF = MAC address 0
- If you do not change device instance in program mode, it will be automatically modified according to the MAC address.

MAC Address	DS.1 = 1	DS.2 = 2	DS.3 = 4	DS.4 = 8	DS.5 = 16	DS.6 = 32	DS.7 = 64	DS.8 = 128	Default Device Instance
0	OFF	OFF	OFF	OFF	OFF	OFF	OFF	OFF	153000
1	ON	OFF	OFF	OFF	OFF	OFF	OFF	OFF	153001
2	OFF	ON	OFF	OFF	OFF	OFF	OFF	OFF	153002
3	ON	ON	OFF	OFF	OFF	OFF	OFF	OFF	153003
4	OFF	OFF	ON	OFF	OFF	OFF	OFF	OFF	153004
...	...	...	...	...	...	...	...	...	...
126	OFF	ON	ON	ON	ON	ON	ON	OFF	153126
...	...	...	...	...	...	...	...	...	...
254	OFF	ON	ON	ON	ON	ON	ON	ON	153254

#### Modbus

- Highest MAC address is 247.
- Default is all switches OFF = MAC address 1
- MAC address is **binary value +1**
- There is no device instance for Modbus.

MAC Address	DS.1 = 1	DS.2 = 2	DS.3 = 4	DS.4 = 8	DS.5 = 16	DS.6 = 32	DS.7 = 64	DS.8 = 128
0+1 = 1	OFF	OFF	OFF	OFF	OFF	OFF	OFF	OFF
1+1 = 2	ON	OFF	OFF	OFF	OFF	OFF	OFF	OFF
2+1 = 3	OFF	ON	OFF	OFF	OFF	OFF	OFF	OFF
3+1 = 4	ON	ON	OFF	OFF	OFF	OFF	OFF	OFF
4+1 = 5	OFF	OFF	ON	OFF	OFF	OFF	OFF	OFF
...	...	...	...	...	...	...	...	...
126+1 = 127	OFF	ON	ON	ON	ON	ON	ON	OFF
...	...	...	...	...	...	...	...	...
246+1 = 247	OFF	ON	ON	OFF	ON	ON	ON	ON

### LEDs

#### Power

- On = Input voltage normal
- Off = No power

#### Status

- Flashing = Normal operation (watchdog)

#### RX/TX (BACnet)

- Flashing = Receiving (RX) and/or transmitting (TX) data.

#### RX/TX (Modbus)

- Flashing = Receiving (RX) and/or transmitting (TX) data.

#### Input Status

- On = Input on
- Off = Input off
- Flashing = Input not connected (thermistor setting only)
- Analog = When Universal Inputs are set to analog values (Vdc, mA, or 10KΩ); the LED intensity corresponds to the input value. For example: At 10Vdc, the LED will be fully on. At 5Vdc, the LED will be at 50% intensity. At 0 Vdc, the LED will be off.

#### Output Status

- On = Activated
- Off = Deactivated
- Flashing = Output pulsed
- Analog = When Universal and Analog outputs are set to analog values (Vdc or mA); the LED intensity corresponds to the output value. For example: At 10Vdc, the LED will be fully on. At 5Vdc, the LED will be at 50% intensity. At 0 Vdc, the LED will be off.

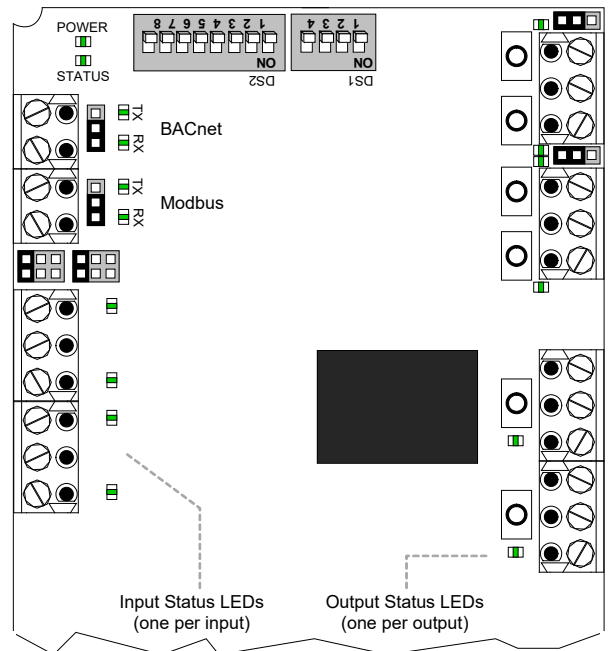

### Network Conditions

Please note that all jumper settings must also be set to the same value through BACnet or Modbus. The following is a list of conditions and additional BACnet or Modbus objects.

#### Universal Inputs (AI1-AI8)

- When the jumper is set to Thermistor, you can select either °C or °F or you can set the input as a digital on/off input.
- If the universal input is set as a digital on/off input, you can also set the polarity to direct or reverse. For example, in Reverse an “on” signal would be recognized as an “off” signal.
- When the jumper is set to 0-10 Vdc, you can also set the range to 0-5 Vdc.

#### Digital Inputs (DI1-DI2)

- You can set the polarity to direct or reverse. For example, in Reverse an “on” signal would be recognized as an “off” signal.

#### Universal/Analog Outputs (AO1-AO4)

- You can set the polarity to direct or reverse. For example, in reverse the output range would be 10-0 Vdc instead of 0-10 Vdc. The polarity applies to all settings 0-10Vdc, 4-20mA, on/off and pulsed.
- You can also set the outputs to pulsed or digital on/off.
- A fixed output value can only be modified via BACnet when the override switch is in the “Automatic” position.

#### Digital Outputs (DO1-DO6)

- A fixed output (open/closed) can only be modified via BACnet when the override switch is in the “Automatic” position.
- The displayed text can be set to either Open/Closed, On/Off, or Alarm/Normal (BACnet only).

#### Supervised Outputs

- All outputs are fully supervised via BACnet. This provides the actual state of the output including any manual overrides done using the on-board switches.

### BACnet Objects Table

ID <sup>1</sup>	Name	Description	Writable?	Notes (* = default) († = only when <i>UniversalInputFunction</i> is set to 10K_Type3/G)
AI.1	UniversalInput1	Universal input 1 mode selected by MSV.1	Out of service	0 to 10Volt or -40 to 100°C (150°C) <sup>†</sup> or -40 to 212°F (302°F) <sup>†</sup> or 4 to 20mA or 0 to 1 Resolution: 0.01Volt or 0.01°C/0.02°F or 0.01mA or 1
AI.2	UniversalInput2	Universal input 2 mode selected by MSV.12	Out of service	0 to 10Volt or -40 to 100°C (150°C) <sup>†</sup> or -40 to 212°F (302°F) <sup>†</sup> or 4 to 20mA or 0 to 1 Resolution: 0.01Volt or 0.01°C/0.02°F or 0.01mA or 1
AI.3	UniversalInput3	Universal input 3 mode selected by MSV.15	Out of service	0 to 10Volt or -40 to 100°C (150°C) <sup>†</sup> or -40 to 212°F (302°F) <sup>†</sup> or 4 to 20mA or 0 to 1 Resolution: 0.01Volt or 0.01°C/0.02°F or 0.01mA or 1
AI.4	UniversalInput4	Universal input 4 mode selected by MSV.48	Out of service	0 to 10Volt or -40 to 100°C (150°C) <sup>†</sup> or -40 to 212°F (302°F) <sup>†</sup> or 4 to 20mA or 0 to 1 Resolution: 0.01Volt or 0.01°C/0.02°F or 0.01mA or 1
AI.5	UniversalInput5	Universal input 5 mode selected by MSV.57	Out of service	0 to 10Volt or -40 to 100°C (150°C) <sup>†</sup> or -40 to 212°F (302°F) <sup>†</sup> or 4 to 20mA or 0 to 1 Resolution: 0.01Volt or 0.01°C/0.02°F or 0.01mA or 1
AI.6	UniversalInput6	Universal input 6 mode selected by MSV.58	Out of service	0 to 10Volt or -40 to 100°C (150°C) <sup>†</sup> or -40 to 212°F (302°F) <sup>†</sup> or 4 to 20mA or 0 to 1 Resolution: 0.01Volt or 0.01°C/0.02°F or 0.01mA or 1
AI.7	UniversalInput7	Universal input 7 mode selected by MSV.59	Out of service	0 to 10Volt or -40 to 100°C (150°C) <sup>†</sup> or -40 to 212°F (302°F) <sup>†</sup> or 4 to 20mA or 0 to 1 Resolution: 0.01Volt or 0.01°C/0.02°F or 0.01mA or 1
AI.8	UniversalInput8	Universal input 8 mode selected by MSV.60	Out of service	0 to 10Volt or -40 to 100°C (150°C) <sup>†</sup> or -40 to 212°F (302°F) <sup>†</sup> or 4 to 20mA or 0 to 1 Resolution: 0.01Volt or 0.01°C/0.02°F or 0.01mA or 1
AV.52	AnalogOutput1Min	Min. voltage of analog output 1	Present Value	0* Volt to AV.54   Resolution 0.1 Volt
AV.53	AnalogOutput2Min	Min. voltage of analog output 2	Present Value	0* Volt to AV.55   Resolution 0.1 Volt
AV.54	AnalogOutput1Max	Max. voltage of analog output 1	Present Value	AV.52 to 10.0* Volt   Resolution 0.1 Volt
AV.55	AnalogOutput2Max	Max. voltage of analog output 2	Present Value	AV.53 to 10.0* Volt   Resolution 0.1 Volt

<sup>1</sup> ID is equal to ObjectType.Instance

ID <sup>1</sup>	Name	Description	Writable?	Notes (* = default) († = only when <i>UniversalInputxFunction</i> is set to 10K_Type3/G)
AV.72	AnalogOutput1	Analog output 1 value	Present Value	0-100%   Resolution 0.1%
AV.73	AnalogOutput2	Analog output 2 value	Present Value	0-100%   Resolution 0.1%
AV.118	AnalogOutput3Min	Min. voltage of analog output 3	Present Value	0* Volt to AV.120   Resolution 0.1 Volt
AV.119	AnalogOutput4Min	Min. voltage of analog output 4	Present Value	0* Volt to AV.121   Resolution 0.1 Volt
AV.120	AnalogOutput3Max	Max. voltage of analog output 3	Present Value	AV.118 to 10.0* Volt   Resolution 0.1 Volt
AV.121	AnalogOutput4Max	Max. voltage of analog output 4	Present Value	AV.119 to 10.0* Volt   Resolution 0.1 Volt
AV.124	AnalogOutput3	Analog output 3 value	Present Value	0-100%   Resolution 1%
AV.125	AnalogOutput4	Analog output 4 value	Present Value	0-100%   Resolution 1%
AV.226	UniversalInput1Offset	Universal input 1 offset	Present Value	-5.00 to 5.00 °C/°F/Volt/mA (default 0*) Resolution: 0.01 °C/°F/Volt/mA
AV.227	UniversalInput2Offset	Universal input 2 offset	Present Value	-5.00 to 5.00 °C/°F/Volt/mA (default 0*) Resolution: 0.01 °C/°F/Volt/mA
AV.228	UniversalInput3Offset	Universal input 3 offset	Present Value	-5.00 to 5.00 °C/°F/Volt/mA (default 0*) Resolution: 0.01 °C/°F/Volt/mA
AV.229	UniversalInput4Offset	Universal input 4 offset	Present Value	-5.00 to 5.00 °C/°F/Volt/mA (default 0*) Resolution: 0.01 °C/°F/Volt/mA
AV.230	UniversalInput5Offset	Universal input 5 offset	Present Value	-5.00 to 5.00 °C/°F/Volt/mA (default 0*) Resolution: 0.01 °C/°F/Volt/mA
AV.231	UniversalInput6Offset	Universal input 6 offset	Present Value	-5.00 to 5.00 °C/°F/Volt/mA (default 0*) Resolution: 0.01 °C/°F/Volt/mA
AV.232	UniversalInput7Offset	Universal input 7 offset	Present Value	-5.00 to 5.00 °C/°F/Volt/mA (default 0*) Resolution: 0.01 °C/°F/Volt/mA
AV.233	UniversalInput8Offset	Universal input 8 offset	Present Value	-5.00 to 5.00 °C/°F/Volt/mA (default 0*) Resolution: 0.01 °C/°F/Volt/mA
AV.235	SD1_Type_ADD	Remote sensor model and Modbus address		See STLD24 document for information
AV.236	SD1_Baudrate	Remote sensor baud rate of Modbus communication	Present Value	See STLD24 document for information
AV.237	SD1_Firmware_version	Remote sensor version		See STLD24 document for information
AV.238	SD1_Status_Config	Remote sensor config and status	Present Value	See STLD24 document for information
AV.239	SD1_Intern_Temp	Remote sensor internal temp.		See STLD24 document for information
AV.240	SD1_Temp_SetPoint	Remote sensor temp. setpoint	Present Value	See STLD24 document for information
AV.241	SD1_Min_Temp_SetPoint	Remote sensor min. setpoint	Present Value	See STLD24 document for information
AV.242	SD1_Max_Temp_SetPoint	Remote sensor max. setpoint	Present Value	See STLD24 document for information
AV.243	SD1_Int_Temp_Offset	Remote sensor internal temperature offset	Present Value	See STLD24 document for information
AV.249	SD1_Extern_Temp	Remote sensor external temp.		See STLD24 document for information
AV.250	SD1_Extern_Temp_Offset	Remote sensor external temperature offset	Present Value	See STLD24 document for information
AV.251	SD1_Button_Cfg_Status	Remote sensor button configuration and status	Present Value	See STLD24 document for information
AV.252	SD1_Let76	Remote sensor text characters 7 and 6	Present Value	See STLD24 document for information
AV.253	SD1_Let54	Remote sensor text characters 5 and 4	Present Value	See STLD24 document for information
AV.254	SD1_Let32	Remote sensor text characters 3 and 2	Present Value	See STLD24 document for information
AV.255	SD1_Let1	Remote sensor text character 1	Present Value	See STLD24 document for information
AV.256	SD1_Digit43	Remote sensor digit number 4 and 3	Present Value	See STLD24 document for information
AV.257	SD1_Digit21	Remote sensor digit number 2 and 1	Present Value	See STLD24 document for information
AV.258	SD1_Icon1	Remote sensor icon to display	Present Value	See STLD24 document for information
AV.259	SD1_Icon1_Blink	Remote sensor icon to blink	Present Value	See STLD24 document for information
AV.260	SD1_Icon2	Remote sensor icon to display	Present Value	See STLD24 document for information
AV.261	SD1_Icon2_Blink	Remote sensor icon to blink	Present Value	See STLD24 document for information
AV.262	SD1_Icon3	Remote sensor icon to display	Present Value	See STLD24 document for information
AV.263	SD1_Icon3_Blink	Remote sensor icon to blink	Present Value	See STLD24 document for information

ID <sup>1</sup>	Name	Description	Writable?	Notes (* = default) († = only when <i>UniversalInputFunction</i> is set to 10K_Type3/G)
AV.264	SD2_Type_ADD	Remote sensor model and Modbus address		See STLD24 document for information
AV.265	SD2_Baudrate	Remote sensor baud rate of Modbus communication	Present Value	See STLD24 document for information
AV.266	SD2_Firmware_version	Remote sensor version		See STLD24 document for information
AV.267	SD2_Status_Config	Remote sensor config and status	Present Value	See STLD24 document for information
AV.268	SD2_Intern_Temp	Remote sensor internal temp.		See STLD24 document for information
AV.269	SD2_Temp_SetPoint	Remote sensor temp. setpoint	Present Value	See STLD24 document for information
AV.270	SD2_Min_Temp_SetPoint	Remote sensor min. setpoint	Present Value	See STLD24 document for information
AV.271	SD2_Max_Temp_SetPoint	Remote sensor max. setpoint	Present Value	See STLD24 document for information
AV.272	SD2_Int_Temp_Offset	Remote sensor internal temperature offset	Present Value	See STLD24 document for information
AV.278	SD2_Extern_Temp	Remote sensor external temp.		See STLD24 document for information
AV.279	SD2_Extern_Temp_Offset	Remote sensor external temperature offset	Present Value	See STLD24 document for information
AV.280	SD2_Button_Cfg_Status	Remote sensor button configuration and status	Present Value	See STLD24 document for information
AV.281	SD2_Let76	Remote sensor text characters 7 and 6	Present Value	See STLD24 document for information
AV.282	SD2_Let54	Remote sensor text characters 5 and 4	Present Value	See STLD24 document for information
AV.283	SD2_Let32	Remote sensor text characters 3 and 2	Present Value	See STLD24 document for information
AV.284	SD2_Let1	Remote sensor text character 1	Present Value	See STLD24 document for information
AV.285	SD2_Digit43	Remote sensor digit number 4 and 3	Present Value	See STLD24 document for information
AV.286	SD2_Digit21	Remote sensor digit number 4 and 3	Present Value	See STLD24 document for information
AV.287	SD2_Icon1	Remote sensor icon to display	Present Value	See STLD24 document for information
AV.288	SD2_Icon1_Blink	Remote sensor icon to blink	Present Value	See STLD24 document for information
AV.289	SD2_Icon2	Remote sensor icon to display	Present Value	See STLD24 document for information
AV.290	SD2_Icon2_Blink	Remote sensor icon to blink	Present Value	See STLD24 document for information
AV.291	SD2_Icon3	Remote sensor icon to display	Present Value	See STLD24 document for information
AV.292	SD2_Icon3_Blink	Remote sensor icon to blink	Present Value	See STLD24 document for information
AV.467	NumberOfSlaveSensor	Number of remote sensors	Present Value	0*-2 (# of STLD24 connected to CMMB)
AV.468	CopyCfgStartAdd	Copy configuration start address	Present Value	0-254 Address of first CMMB to copy Available only if BV.101 is set to No
AV.469	CopyCfgEndAdd	Copy configuration end address	Present Value	AV.468 – (AV.468 + 64) Address of last CMMB to copy Available only if BV.101 is set to No
AV.470	CopyCfgResult <sup>2</sup>	Copy configuration result	Present Value	AV.468 – AV.469 Result of copy is available on Description property and is available only if BV.101 is set to Yes. Results: Succeed, Prog_Error, Type_Error, Model_Error, FW_Error, Mem_Error, Size_Error, Comm_Error, SlaveDevice, InProgress, AllSucceed
AV.500	U1_MinInputValue	Universal input 1 minimum input value	Present Value	0-10Volt or 4-20mA, Resolution: 0.01Volt or 0.01mA
AV.501	U1_MaxInputValue	Universal input 1 maximum input value	Present Value	0-10Volt or 4-20mA, Resolution: 0.01Volt or 0.01mA
AV.502	U1_MinValue	Universal input 1 minimum scaled value	Present Value	-32768 to 32767, Resolution: 0.01
AV.503	U1_MaxValue	Universal input 1 maximum scaled value	Present Value	-32768 to 32767, Resolution: 0.01
AV.504	U2_MinInputValue	Universal input 2 minimum input value	Present Value	0-10Volt or 4-20mA, Resolution: 0.01Volt or 0.01mA
AV.505	U2_MaxInputValue	Universal input 2 maximum input value	Present Value	0-10Volt or 4-20mA, Resolution: 0.01Volt or 0.01mA

<sup>2</sup> Write 526address in present value, result will be available in description.

ID <sup>1</sup>	Name	Description	Writable?	Notes (* = default) (* = only when <i>UniversalInputxFunction</i> is set to <i>10K_Type3/G</i> )
AV.506	U2_MinValue	Universal input 2 minimum scaled value	Present Value	-32768 to 32767, Resolution: 0.01
AV.507	U2_MaxValue	Universal input 2 maximum scaled value	Present Value	-32768 to 32767, Resolution: 0.01
AV.508	U3_MinInputValue	Universal input 3 minimum input value	Present Value	0-10Volt or 4-20mA, Resolution: 0.01Volt or 0.01mA
AV.509	U3_MaxInputValue	Universal input 3 maximum input value	Present Value	0-10Volt or 4-20mA, Resolution: 0.01Volt or 0.01mA
AV.510	U3_MinValue	Universal input 3 minimum scaled value	Present Value	-32768 to 32767, Resolution: 0.01
AV.511	U3_MaxValue	Universal input 3 maximum scaled value	Present Value	-32768 to 32767, Resolution: 0.01
AV.512	U4_MinInputValue	Universal input 4 minimum input value	Present Value	0-10Volt or 4-20mA, Resolution: 0.01Volt or 0.01mA
AV.513	U4_MaxInputValue	Universal input 4 maximum input value	Present Value	0-10Volt or 4-20mA, Resolution: 0.01Volt or 0.01mA
AV.514	U4_MinValue	Universal input 4 minimum scaled value	Present Value	-32768 to 32767, Resolution: 0.01
AV.515	U4_MaxValue	Universal input 4 maximum scaled value	Present Value	-32768 to 32767, Resolution: 0.01
AV.516	U5_MinInputValue	Universal input 5 minimum input value	Present Value	0-10Volt or 4-20mA, Resolution: 0.01Volt or 0.01mA
AV.517	U5_MaxInputValue	Universal input 5 maximum input value	Present Value	0-10Volt or 4-20mA, Resolution: 0.01Volt or 0.01mA
AV.518	U5_MinValue	Universal input 5 minimum scaled value	Present Value	-32768 to 32767, Resolution: 0.01
AV.519	U5_MaxValue	Universal input 5 maximum scaled value	Present Value	-32768 to 32767, Resolution: 0.01
AV.520	U6_MinInputValue	Universal input 6 minimum input value	Present Value	0-10Volt or 4-20mA, Resolution: 0.01Volt or 0.01mA
AV.521	U6_MaxInputValue	Universal input 6 maximum input value	Present Value	0-10Volt or 4-20mA, Resolution: 0.01Volt or 0.01mA
AV.522	U6_MinValue	Universal input 6 minimum scaled value	Present Value	-32768 to 32767, Resolution: 0.01
AV.523	U6_MaxValue	Universal input 6 maximum scaled value	Present Value	-32768 to 32767, Resolution: 0.01
AV.524	U7_MinInputValue	Universal input 7 minimum input value	Present Value	0-10Volt or 4-20mA, Resolution: 0.01Volt or 0.01mA
AV.525	U7_MaxInputValue	Universal input 7 maximum input value	Present Value	0-10Volt or 4-20mA, Resolution: 0.01Volt or 0.01mA
AV.526	U7_MinValue	Universal input 7 minimum scaled value	Present Value	-32768 to 32767, Resolution: 0.01
AV.527	U7_MaxValue	Universal input 7 maximum scaled value	Present Value	-32768 to 32767, Resolution: 0.01
AV.528	U8_MinInputValue	Universal input 8 minimum input value	Present Value	0-10Volt or 4-20mA, Resolution: 0.01Volt or 0.01mA
AV.529	U8_MaxInputValue	Universal input 8 maximum input value	Present Value	0-10Volt or 4-20mA, Resolution: 0.01Volt or 0.01mA
AV.530	U8_MinValue	Universal input 8 minimum scaled value	Present Value	-32768 to 32767, Resolution: 0.01
AV.531	U8_MaxValue	Universal input 8 maximum scaled value	Present Value	-32768 to 32767, Resolution: 0.01
BI.1	DigitalInput1	Digital input 1 status	Out of service	0= Open / Ouvert * 1= Close / Fermé Text depends of selection in MSV.76
BI.2	DigitalInput2	Digital input 2 status	Out of service	0= Open / Ouvert * 1= Close / Fermé Text depends of selection in MSV.77
BV.22	ContactOutput1	Digital output 1 status	Present Value	0= Open / Ouvert / Off / Arret / Normal * 1= Close / Fermé / On / Marche / Alarm Text depends of selection in MSV.66
BV.23	ContactOutput2	Digital output 2 status	Present Value	0= Open / Ouvert / Off / Arret / Normal * 1= Close / Fermé / On / Marche / Alarm Text depends of selection in MSV.67



ID <sup>1</sup>	Name	Description	Writable?	Notes (* = default) († = only when <b>UniversalInputxFunction</b> is set to <b>10K_Type3/G</b> )
<b>BV.24</b>	ContactOutput3	Digital output 3 status	Present Value	0= Open / Ouvert / Off / Arret / Normal * 1= Close / Fermé / On / Marche / Alarm Text depends of selection in MSV.68
<b>BV.25</b>	ContactOutput4	Digital output 4 status	Present Value	0= Open / Ouvert / Off / Arret / Normal * 1= Close / Fermé / On / Marche / Alarm Text depends of selection in MSV.69
<b>BV.26</b>	ContactOutput5	Digital output 5 status	Present Value	0= Open / Ouvert / Off / Arret / Normal * 1= Close / Fermé / On / Marche / Alarm Text depends of selection in MSV.70
<b>BV.27</b>	ContactOutput6	Digital output 6 status	Present Value	0= Open / Ouvert / Off / Arret / Normal * 1= Close / Fermé / On / Marche / Alarm Text depends of selection in MSV.71
<b>BV.33</b>	DigitalInput1Polarity	Polarity of digital input 1	Present Value	0= Direct * 1= Reverse
<b>BV.34</b>	DigitalInput2Polarity	Polarity of digital input 2	Present Value	0= Direct * 1= Reverse
<b>BV.66</b>	AnalogOutput1Direction	Polarity of analog output 1	Present Value	0= Direct * 1= Reverse
<b>BV.67</b>	AnalogOutput2Direction	Polarity of analog output 2	Present Value	0= Direct * 1= Reverse
<b>BV.68</b>	AnalogOutput3Direction	Polarity of analog output 3	Present Value	0= Direct * 1= Reverse
<b>BV.69</b>	AnalogOutput4Direction	Polarity of analog output 4	Present Value	0= Direct * 1= Reverse
<b>BV.93</b>	UI1_DI_Polarity	Polarity of universal input 1 when used in digital input mode	Present Value	0= Direct * 1= Reverse
<b>BV.94</b>	UI2_DI_Polarity	Polarity of universal input 2 when used in digital input mode	Present Value	0= Direct * 1= Reverse
<b>BV.95</b>	UI3_DI_Polarity	Polarity of universal input 3 when used in digital input mode	Present Value	0= Direct * 1= Reverse
<b>BV.96</b>	UI4_DI_Polarity	Polarity of universal input 4 when used in digital input mode	Present Value	0= Direct * 1= Reverse
<b>BV.97</b>	UI5_DI_Polarity	Polarity of universal input 5 when used in digital input mode	Present Value	0= Direct * 1= Reverse
<b>BV.98</b>	UI6_DI_Polarity	Polarity of universal input 6 when used in digital input mode	Present Value	0= Direct * 1= Reverse
<b>BV.99</b>	UI7_DI_Polarity	Polarity of universal input 7 when used in digital input mode	Present Value	0= Direct * 1= Reverse
<b>BV.100</b>	UI8_DI_Polarity	Polarity of universal input 8 when used in digital input mode	Present Value	0= Direct * 1= Reverse
<b>BV.101</b>	CopyCfgExecute	Start or stop copy configuration	Present Value	0= No * 1= Yes Start copy and give results, must be reset by user.
<b>BV.102</b>	SystemUnit	Select the unit system to use on the device	Present Value	0= Celsius * 1= Fahrenheit
<b>BV.103</b>	Inhibit Output Override	Inhibit the override of the outputs	Present Value	0= Off * 1= On
<b>MSV.1</b>	UniversalInput1Function	Selected analog input 1 mode	Present Value	1= 0_10Volt 2= 4_20mA <b>3= 10K_Type3/G *</b> 4= 10K_Type3A1 5= 10K_Type4A1 <b>6= 10K_Type2</b> 7= 20K_Type6A1 8= 30K_Type6A1 9= DigitalInput 10= ScaledValue_Volt 11= ScaledValue_mA

ID <sup>1</sup>	Name	Description	Writable?	Notes (* = default) († = only when <i>UniversalInputxFunction</i> is set to <i>10K_Type3/G</i> )
MSV.12	UniversalInput2Function	Selected analog input 2 mode	Present Value	1= 0_10Volt 2= 4_20mA 3= 10K_Type3/G * 4= 10K_Type3A1 5= 10K_Type4A1 6= 10K_Type2 7= 20K_Type6A1 8= 30K_Type6A1 9= DigitalInput 10= ScaledValue_Volt 11= ScaledValue_mA
MSV.15	UniversalInput3Function	Selected analog input 3 mode	Present Value	1= 0_10Volt 2= 4_20mA 3= 10K_Type3/G * 4= 10K_Type3A1 5= 10K_Type4A1 6= 10K_Type2 7= 20K_Type6A1 8= 30K_Type6A1 9= DigitalInput 10= ScaledValue_Volt 11= ScaledValue_mA
MSV.48	UniversalInput4Function	Selected analog input 4 mode	Present Value	1= 0_10Volt 2= 4_20mA 3= 10K_Type3/G * 4= 10K_Type3A1 5= 10K_Type4A1 6= 10K_Type2 7= 20K_Type6A1 8= 30K_Type6A1 9= DigitalInput 10= ScaledValue_Volt 11= ScaledValue_mA
MSV.54	AnalogOutput1Mode	Select analog output 1 mode	Present Value	1= Analog * 2= On_Off 3= Pulsing
MSV.55	AnalogOutput2Mode	Select analog output 2 mode	Present Value	1= Analog * 2= On_Off 3= Pulsing
MSV.57	UniversalInput5Function	Selected analog input 5 mode	Present Value	1= 0_10Volt 2= 4_20mA 3= 10K_Type3/G * 4= 10K_Type3A1 5= 10K_Type4A1 6= 10K_Type2 7= 20K_Type6A1 8= 30K_Type6A1 9= DigitalInput 10= ScaledValue_Volt 11= ScaledValue_mA
MSV.58	UniversalInput6Function	Selected analog input 6 mode	Present Value	1= 0_10Volt 2= 4_20mA 3= 10K_Type3/G * 4= 10K_Type3A1 5= 10K_Type4A1 6= 10K_Type2 7= 20K_Type6A1 8= 30K_Type6A1 9= DigitalInput 10= ScaledValue_Volt 11= ScaledValue_mA
MSV.59	UniversalInput7Function	Selected analog input 7 mode	Present Value	1= 0_10Volt 2= 4_20mA 3= 10K_Type3/G * 4= 10K_Type3A1 5= 10K_Type4A1 6= 10K_Type2 7= 20K_Type6A1 8= 30K_Type6A1 9= DigitalInput 10= ScaledValue_Volt 11= ScaledValue_mA

ID <sup>1</sup>	Name	Description	Writable?	Notes (* = default) († = only when <i>UniversalInputxFunction</i> is set to <i>10K_Type3/G</i> )
<b>MSV.60</b>	UniversalInput8Function	Selected analog input 8 mode	Present Value	1= 0_10Volt 2= 4_20mA 3= 10K_Type3/G * 4= 10K_Type3A1 5= 10K_Type4A1 6= 10K_Type2 7= 20K_Type6A1 8= 30K_Type6A1 9= DigitalInput 10= ScaledValue_Volt 11= ScaledValue_mA
<b>MSV.66</b>	ContactOutput1Text	Contact output 1 inactive & active text	Present Value	1= Open_Close * 2= Ouvert_Fermé 3= On_Off 4= Marche_Arret 5= Alarm_Normal
<b>MSV.67</b>	ContactOutput2Text	Contact output 2 inactive & active text	Present Value	1= Open_Close * 2= Ouvert_Fermé 3= On_Off 4= Marche_Arret 5= Alarm_Normal
<b>MSV.68</b>	ContactOutput3Text	Contact output 3 inactive & active text	Present Value	1= Open_Close * 2= Ouvert_Fermé 3= On_Off 4= Marche_Arret 5= Alarm_Normal
<b>MSV.69</b>	ContactOutput4Text	Contact output 4 inactive & active text	Present Value	1= Open_Close * 2= Ouvert_Fermé 3= On_Off 4= Marche_Arret 5= Alarm_Normal
<b>MSV.70</b>	ContactOutput5Text	Contact output 5 inactive & active text	Present Value	1= Open_Close * 2= Ouvert_Fermé 3= On_Off 4= Marche_Arret 5= Alarm_Normal
<b>MSV.71</b>	ContactOutput6Text	Contact output 6 inactive & active text	Present Value	1= Open_Close * 2= Ouvert_Fermé 3= On_Off 4= Marche_Arret 5= Alarm_Normal
<b>MSV.76</b>	DigitalInput1Text	Digital input 1 inactive & active text	Present Value	1= Open_Close * 2= Ouvert_Fermé
<b>MSV.77</b>	DigitalInput2Text	Digital input 2 inactive & active text	Present Value	1= Open_Close * 2= Ouvert_Fermé
<b>MSV.81</b>	AnalogOutput3Mode	Select analog output 3 mode	Present Value	1= Analog * 2= On_Off 3= Pulsing 4= 4_20mA
<b>MSV.82</b>	AnalogOutput4Mode	Select analog output 4 mode	Present Value	1= Analog * 2= On_Off 3= Pulsing 4= 4_20mA

### Modbus Registers

- Register address
  - As per protocol base (base 0); for PLC add 1 to protocol base.
  - As per holding register (base 40001)
- Functions :
  - 03 Read Holding Register
  - 06 Write Single Register
  - 16 Write Multiple Registers
- Error Codes :
  - 02 Illegal Data Address
  - 03 Illegal Value
  - 06 Slave Device Busy
- W = Writable register, [blank] = read only.
- No Real number in modbus register, use scale to calculate real number. Register = Real number \* Scale => Real number = Register / Scale. Scale could be 1, 10 or 100
- Attention when writing a register that contains a bit string. If bit is writable (conditional or not), the write will always be accepted. If bit is reserved or not writable, the write will be ignored and will keep its actual state.
- Use READ-MODIFY-WRITE sequence.

Protocol Base	Holding Register	Description	Data Type	MSB/LSB		Units/Values	Writable	Default Value	
								MB	LB
0	40001	MSB = Device ID LSB = MAC Address	Unsigned	105 (69h)	[1..247] (1h- F7h)	* MAC address is writable if all DIP switches of DS2 are OFF.	W*	69h	1h
1	40002	Device Baud Rate	Unsigned Scale 0.01	[96] [192] [384] [576]		9,600 19,200 38,400 57,600	W	96	
2	40003	COM Port Configuration <b>IMPORTANT:</b> The default value is "no parity, 2 stop bits". To change the value, you must set DIP switch DS1-3 to OFF. If set to ON, it will always remain at the default value. Refer to Connections and Configurations on page 2.	Unsigned	[0..2]		0 = no parity, 2 stop bits 1 = even parity, 1 stop bit 2 = odd parity, 1 stop bit	W	0	
3	40004	Product Name (characters 8 & 7)	2 x ASCII	char 8	char 7	Valid ASCII character: 32 (20h) – 122 (7ah), Empty = 0	W	43h [C]	40h [M]
4	40005	Product Name (characters 6 & 5)	2 x ASCII	char 6	char 5	Valid ASCII character: 32 (20h) – 122 (7ah), Empty = 0	W	40h [M]	42h [B]
5	40006	Product Name (characters 4 & 3)	2 x ASCII	char 4	char 3	Valid ASCII character: 32 (20h) – 122 (7ah), Empty = 0	W	31h [1]	30h [0]
6	40007	Product Name (characters 2 & 1)	2 x ASCII	char 2	char 1	Valid ASCII character: 32 (20h) – 122 (7ah), Empty = 0	W	36h [6]	20h [ ]
7	40008	Firmware Version	Unsigned Scale 100	<b>112</b>		<b>1.12</b>		<b>112</b>	
8	40009	Application Version	Unsigned	103		1.03		103	

Protocol Base	Holding Register	Description	Data Type	MSB/LSB	Units/Values	Writable	Default Value	
							MB	LB
			Scale 100					
9	40010	System Status 1	Bit String	[B0..B15]	0 = Normal 1 = Fault ----- B0 = System operation		0000, 0001, 1111, 1110b	
10	40011	System Status 2	Bit String	[B0..B15]	Always 0		0000, 0000, 0000, 0000b	
11	40012	Analog Input 1	0-10V: Type: Unsigned, Scale:100, Unit: Volt, Range: 0.00-10.00V, Resolution: 0.01				32767	
12	40013	Analog Input 2	4-20mA: Type: Unsigned, Scale:100, Unit: mA, Range: 4.00-20.00 mA, Resolution: 0.01				32767	
13	40014	Analog Input 3	10K Type 3A1, 10K Type 4AI, 10K Type 2, 20K Type 6AI, 30K Type 6AI: Type: Signed, Scale:100, Unit: °C, Range: -40.00 - 100.00 °C, Resolution: 0.01				32767	
14	40015	Analog Input 4	Type: Signed, Scale:100, Unit: °F, Range: -40.00 - 212.00 °F, Resolution: 0.02 10K Type 3/G:				32767	
15	40016	Analog Input 5	Type: Signed, Scale:100, Unit: °C, Range: -40.00 - 150.00 °C, Resolution: 0.01				32767	
16	40017	Analog Input 6	Type: Signed, Scale:100, Unit: °F, Range: -40.00 - 302.00 °F, Resolution: 0.02				32767	
17	40018	Analog Input 7	DI: Type: Unsigned, Scale:1, No Unit, Range: 0-1, Resolution: 1				32767	
18	40019	Analog Input 8	Scaled Input (Volt), Scaled Input (mA): Type: Unsigned, Scale:1, No Unit, Range: Ux_MinValue - Ux_MaxValue, Resolution: 1				32767	
19	40020	Digital Input	Bit String	[B0..B1]	B0 = DI1 B1 = DI2		0000, 0000, 0000, 0000b	
20	40021	Analog Output 1	Unsigned Scale 10	[0..1000]	Unit: %, Range: 0-100.0%, Resolution: 0.1	W	0	
21	40022	Analog Output 2					0	
22	40023	Analog Output 3					0	
23	40024	Analog Output 4					0	
24	40025	Relay Output	Bit String	[B0..B5]	B0 = Relay 1 B1 = Relay 2 B2 = Relay 3 B3 = Relay 4 B4 = Relay 5 B5 = Relay 6	W	0000, 0000, 0000, 0000b	

Protocol Base	Holding Register	Description	Data Type	MSB/LSB	Units/Values	Writable	Default Value	
							MB	LB
25	40026	Output Overwrite Status <i>Indicates that the output is overridden by the hardware switch (SW5-SW10).</i>	Bit String	[B0..B9]	B0 = Relay 1 B1 = Relay 2 B2 = Relay 3 B3 = Relay 4 B4 = Relay 5 B5 = Relay 6 B6 = AO1 B7 = AO2 B8 = AO3 B9 = AO4		0000, 0000, 0000, 0000b	
26	40027	Universal Input 1 Function	Unsigned	[1..11]	1 = 0-10V, 2 = 4-20 mA, 3 = 10K Type 3/G, 4 = 10K Type 3A1, 5 = 10K Type 4A1, 6 = 10K Type 2, 7 = 20K Type 6A1, 8 = 30K Type 6A1, 9 = Digital Input, 10 = Scaled Input (Volt), 11 = Scaled Input (mA)	W	3	
27	40028	Universal Input 2 Function					3	
28	40029	Universal Input 3 Function					3	
29	40030	Universal Input 4 Function					3	
30	40031	Universal Input 5 Function					3	
31	40032	Universal Input 6 Function					3	
32	40033	Universal Input 7 Function					3	
33	40034	Universal Input 8 Function					3	
34	40035	Universal Input 1 Offset	Signed Scale 100	[-500..500]	Range: +/- 5.00, Resolution: 0.10	W	0	
35	40036	Universal Input 2 Offset					0	
36	40037	Universal Input 3 Offset					0	
37	40038	Universal Input 4 Offset					0	
38	40039	Universal Input 5 Offset					0	
39	40040	Universal Input 6 Offset					0	
40	40041	Universal Input 7 Offset					0	
41	40042	Universal Input 8 Offset					0	
42	40043	Analog Output 1 Mode	Unsigned	[1..3]	1 = Analog 2 = On/Off 3 = Pulse	W	1	
43	40044	Analog Output 1 Minimum Voltage	Signed Scale 10	[0..100]	Unit: Volt, Range: 0 V - Register 44, Resolution: 0.1	W	0	
44	40045	Analog Output 1 Maximum Voltage			Unit: Volt, Range: Register 43 - 10.0V, Resolution: 0.1		100	
45	40046	Analog Output 2 Mode	Unsigned	[1..3]	1 = Analog 2 = On/Off	W	1	

Protocol Base	Holding Register	Description	Data Type	MSB/LSB	Units/Values	Writable	Default Value	
							MB	LB
					3 = Pulse			
46	40047	Analog Output 2 Minimum Voltage	Signed Scale 10	[0..100]	Unit: Volt, Range: 0 V - Register 47, Resolution: 0.1	W	0	
47	40048	Analog Output 2 Maximum Voltage			Unit: Volt, Range: Register 46 - 10.0V, Resolution: 0.1		100	
48	40049	Analog Output 3 Mode	Unsigned	[1..4]	1 = Analog 2 = On/Off 3 = Pulse 4 = 4-20mA	W	1	
49	40050	Analog Output 3 Minimum Voltage	Signed Scale 10	[0..100]	Unit: Volt, Range: 0 V - Register 50, Resolution: 0.1	W	0	
50	40051	Analog Output 3 Maximum Voltage			Unit: Volt, Range: Register 49 - 10.0V, Resolution: 0.1		100	
51	40052	Analog Output 4 Mode	Unsigned	[1..4]	1 = Analog 2 = On/Off 3 = Pulse 4 = 4-20mA	W	1	
52	40053	Analog Output 4 Minimum Voltage	Signed Scale 10	[0..100]	Unit: Volt, Range: 0 V - Register 53, Resolution: 0.1	W	0	
53	40054	Analog Output 4 Maximum Voltage			Unit: Volt, Range: Register 52 - 10.0V, Resolution: 0.1		100	
54	40055	System Options <i>* = digital input mode only</i>	Bit String	[B0..B15]	0 = Direct                      0 = Off 1 = Reverse                    1 = On ----- B0 = AO1 polarity              B14 = Inhibit Output Override B1 = AO2 polarity              ----- B2 = AO3 polarity              0 = Celsius B3 = AO4 polarity              1 = Fahrenheit B4 = AI1 polarity *              ----- B5 = AI2 polarity *              B15 = System Unit B6 = AI3 polarity * B7 = AI4 polarity * B8 = AI5 polarity * B9 = AI6 polarity * B10 = AI7 polarity * B11 = AI8 polarity * B12 = DI1 polarity B13 = DI2 polarity	W	0000, 0000, 0000, 0000b	
55	40056	Universal Input 1 Minimum Input Value	Unsigned Scale 100	[0..100]	Unit: Volt, Range: 0.00 V - Register 56, Resolution: 0.01 Unit: mA, Range: 4.00 mA - Register 56, Resolution: 0.01	W	0	
56	40057	Universal Input 1 Maximum Input Value	Unsigned Scale 100	[0..100]	Unit: Volt, Range: Register 55 – 10.00 V, Resolution: 0.01 Unit: mA, Range: Register 55 – 20.00 mA, Resolution: 0.01	W	1000	
57	40058	Universal Input 1 Minimum Value	Signed Scale 1	[-32768...32767]	No Unit, Range: -32768 - Register 58, Resolution: 0.01	W	0	
58	40059	Universal Input 1 Maximum Value	Signed Scale 1	[-32768...32767]	No Unit, Range: Register 57 - 32767, Resolution: 0.01	W	1000	

Protocol Base	Holding Register	Description	Data Type	MSB/LSB	Units/Values	Writable	Default Value	
							MB	LB
59	40060	Universal Input 2 Minimum Input Value	Unsigned Scale 100	[0..100]	Unit: Volt, Range: 0.00 V - Register 60, Resolution: 0.01 Unit: mA, Range: 4.00 mA - Register 60, Resolution: 0.01	W	0	
60	40061	Universal Input 2 Maximum Input Value	Unsigned Scale 100	[0..100]	Unit: Volt, Range: Register 59 – 10.00 V, Resolution: 0.01 Unit: mA, Range: Register 59 – 20.00 mA, Resolution: 0.01	W	1000	
61	40062	Universal Input 2 Minimum Value	Signed Scale 1	[-32768...32767]	No Unit, Range: -32768 - Register 62, Resolution: 0.01	W	0	
62	40063	Universal Input 2 Maximum Value	Signed Scale 1	[-32768...32767]	No Unit, Range: Register 61 - 32767, Resolution: 0.01	W	1000	
63	40064	Universal Input 3 Minimum Input Value	Unsigned Scale 100	[0..100]	Unit: Volt, Range: 0.00 V - Register 64, Resolution: 0.01 Unit: mA, Range: 4.00 mA - Register 64, Resolution: 0.01	W	0	
64	40065	Universal Input 3 Maximum Input Value	Unsigned Scale 100	[0..100]	Unit: Volt, Range: Register 63 – 10.00 V, Resolution: 0.01 Unit: mA, Range: Register 63 – 20.00 mA, Resolution: 0.01	W	1000	
65	40066	Universal Input 3 Minimum Value	Signed Scale 1	[-32768...32767]	No Unit, Range: -32768 - Register 66, Resolution: 0.01	W	0	
66	40067	Universal Input 3 Maximum Value	Signed Scale 1	[-32768...32767]	No Unit, Range: Register 65 - 32767, Resolution: 0.01	W	1000	
67	40068	Universal Input 4 Minimum Input Value	Unsigned Scale 100	[0..100]	Unit: Volt, Range: 0.00 V - Register 68, Resolution: 0.01 Unit: mA, Range: 4.00 mA - Register 68, Resolution: 0.01	W	0	
68	40069	Universal Input 4 Maximum Input Value	Unsigned Scale 100	[0..100]	Unit: Volt, Range: Register 67 – 10.00 V, Resolution: 0.01 Unit: mA, Range: Register 67 – 20.00 mA, Resolution: 0.01	W	1000	
69	40070	Universal Input 4 Minimum Value	Signed Scale 1	[-32768...32767]	No Unit, Range: -32768 - Register 70, Resolution: 0.01	W	0	
70	40071	Universal Input 4 Maximum Value	Signed Scale 1	[-32768...32767]	No Unit, Range: Register 69 - 32767, Resolution: 0.01	W	1000	
71	40072	Universal Input 5 Minimum Input Value	Unsigned Scale 100	[0..100]	Unit: Volt, Range: 0.00 V - Register 72, Resolution: 0.01 Unit: mA, Range: 4.00 mA - Register 72, Resolution: 0.01	W	0	
72	40073	Universal Input 5 Maximum Input Value	Unsigned Scale 100	[0..100]	Unit: Volt, Range: Register 71 – 10.00 V, Resolution: 0.01 Unit: mA, Range: Register 71 – 20.00 mA, Resolution: 0.01	W	1000	
73	40074	Universal Input 5 Minimum Value	Signed Scale 1	[-32768...32767]	No Unit, Range: -32768 - Register 66, Resolution: 0.01	W	0	
74	40075	Universal Input 5 Maximum Value	Signed Scale 1	[-32768...32767]	No Unit, Range: Register 65 - 32767, Resolution: 0.01	W	1000	
75	40076	Universal Input 6 Minimum Input Value	Unsigned Scale 100	[0..100]	Unit: Volt, Range: 0.00 V - Register 64, Resolution: 0.01 Unit: mA, Range : 4.00 mA - Register 64, Resolution: 0.01	W	0	
76	40077	Universal Input 6 Maximum Input Value	Unsigned Scale 100	[0..100]	Unit: Volt, Range: Register 63 – 10.00 V, Resolution: 0.01 Unit: mA, Range: Register 63 – 20.00 mA, Resolution: 0.01	W	1000	
77	40078	Universal Input 6 Minimum Value	Signed Scale 1	[-32768...32767]	No Unit, Range: -32768 - Register 78, Resolution: 0.01	W	0	
78	40079	Universal Input 6 Maximum Value	Signed Scale 1	[-32768...32767]	No Unit, Range: Register 77 - 32767, Resolution: 0.01	W	1000	



Protocol Base	Holding Register	Description	Data Type	MSB/LSB	Units/Values	Writable	Default Value	
							MB	LB
79	40080	Universal Input 7 Minimum Input Value	Unsigned Scale 100	[0..100]	Unit: Volt, Range: 0.00 V - Register 80, Resolution: 0.01 Unit: mA, Range: 4.00 mA - Register 80, Resolution: 0.01	W	0	
80	40081	Universal Input 7 Maximum Input Value	Unsigned Scale 100	[0..100]	Unit: Volt, Range: Register 79 – 10.00 V, Resolution: 0.01 Unit: mA, Range: Register 79 – 20.00 mA, Resolution: 0.01	W	1000	
81	40082	Universal Input 7 Minimum Value	Signed Scale 1	[-32768...32767]	No Unit, Range: -32768 - Register 82, Resolution: 0.01	W	0	
82	40083	Universal Input 7 Maximum Value	Signed Scale 1	[-32768...32767]	No Unit, Range: Register 81 - 32767, Resolution: 0.01	W	1000	
83	40084	Universal Input 8 Minimum Input Value	Unsigned Scale 100	[0..100]	Unit: Volt, Range: 0.00 V - Register 84, Resolution: 0.01 Unit: mA, Range: 4.00 mA - Register 84, Resolution: 0.01	W	0	
84	40085	Universal Input 8 Maximum Input Value	Unsigned Scale 100	[0..100]	Unit: Volt, Range: Register 83 – 10.00 V, Resolution: 0.01 Unit: mA, Range: Register 83 – 20.00 mA, Resolution: 0.01	W	1000	
85	40086	Universal Input 8 Minimum Value	Signed Scale 1	[-32768...32767]	No Unit, Range: -32768 - Register 86, Resolution: 0.01	W	0	
86	40087	Universal Input 8 Maximum Value	Signed Scale 1	[-32768...32767]	No Unit, Range: Register 85 - 32767, Resolution: 0.01	W	1000	



Recycling at end of life: please return this product to your Neptronic local distributor for recycling. If you need to find the nearest Neptronic authorized distributor, please consult [www.neptronic.com](http://www.neptronic.com).



# **Remote I/O Communication Module**

## Specification and Installation Instructions